



Make your own glider

Make a copy of this diagram with tracing paper or cut-out this page from the book. If you cut this page, be sure to read the directions first. Note the instructions on converting this glider to a stunt flyer at the bottom-right of the page.

1. Make a copy of this diagram with tracing paper.

2. Use a manila folder or fold a piece of cardboard. Trace the diagram on it. Place the straight line on the folded edge.

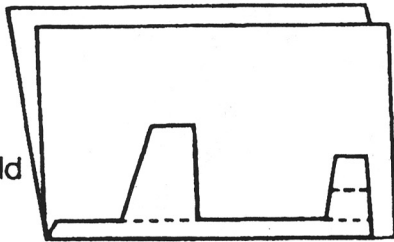

3. Use scissors to cut along the traced line.

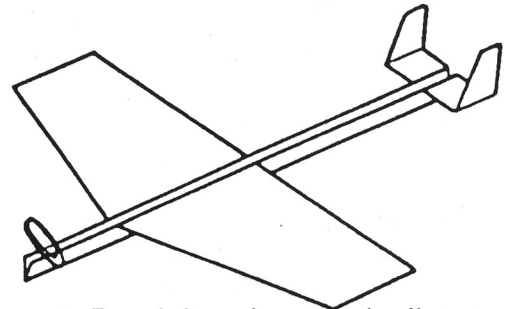
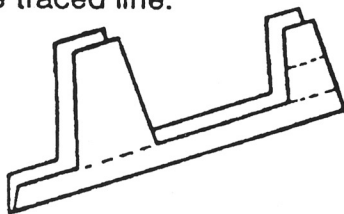

4. Bend the wings and tail as shown. The finished glider should look like this.

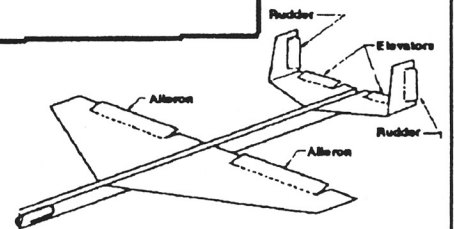
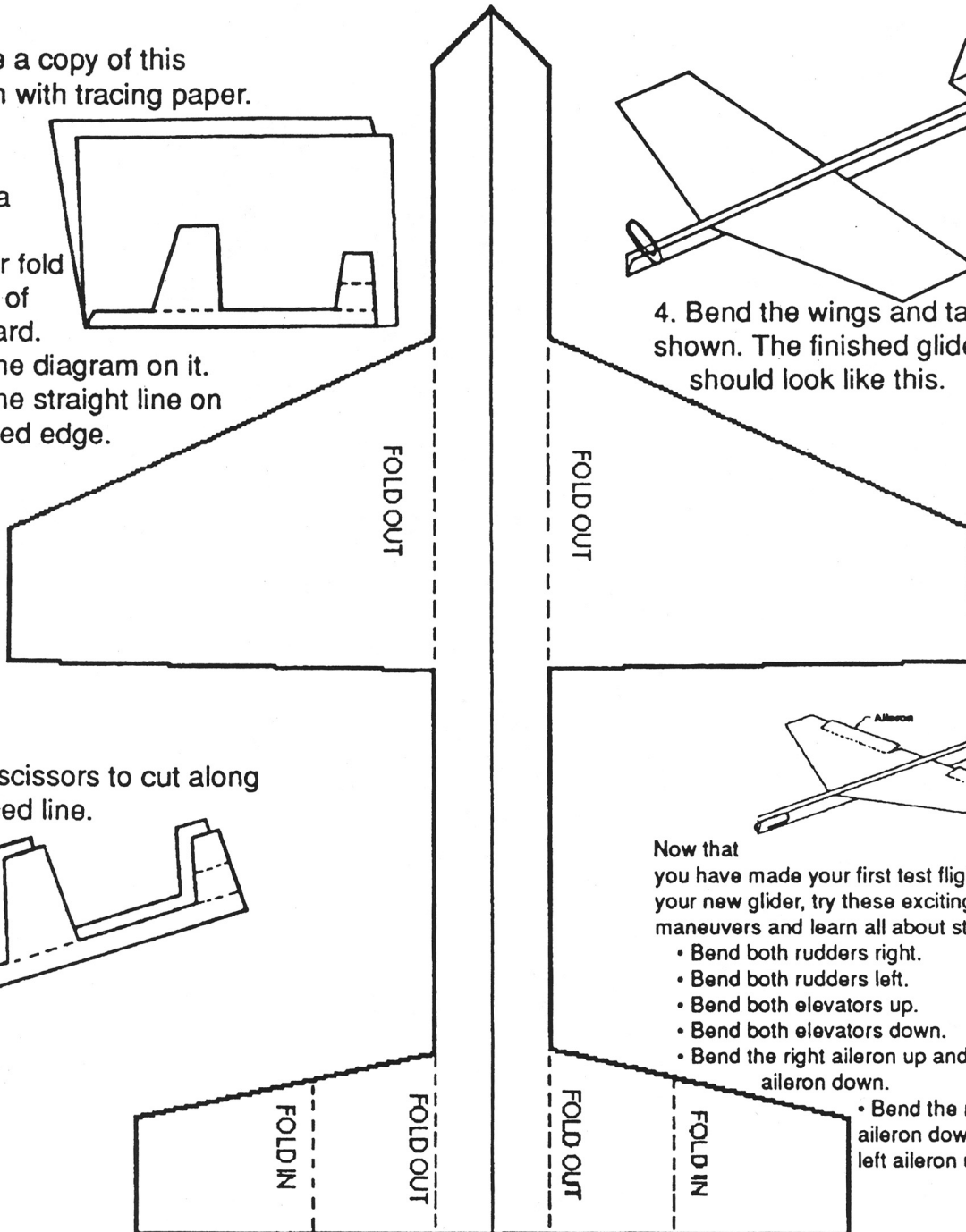

Now that you have made your first test flight with your new glider, try these exciting maneuvers and learn all about stunt flying.

- Bend both rudders right.
- Bend both rudders left.
- Bend both elevators up.
- Bend both elevators down.
- Bend the right aileron up and left aileron down.

- Bend the right aileron down and the left aileron up.